

# TITANROB M501 5-F MINI MANIPULATOR

LOW WEIGHT  
HIGH FORCE  
RELIABLE



**The TitanRob M501 is a five-function hydraulic manipulator made of titanium and developed for Observation- and Light Work Class ROVs. It is a manipulator with enhanced characteristics of weight/power ratio and capabilities: by using titanium as main material, lower weight and more mechanical characteristics are achieved which allows for improved dimensioning.**

Resistant, lightweight, and reliable; it's designed for heavy duty ROV works and robotics which require manipulation operations.

The grabber can be operated by any low power (1kW) HPU and solenoids(x5) valve pack fitted in the ROV vehicle.

## Typical Operations

- ▣ Observation - & Light Weight Work ROV
- ▣ Fish Farming
- ▣ Seabed exploration
- ▣ Seabed mining
- ▣ Robotics

## Features

- ▣ Robust construction
- ▣ Low weight – 11 kg submerged
- ▣ Corrosion resistant materials
- ▣ High force
- ▣ Submersible to 3 000m seawater
- ▣ Service- and user friendly
- ▣ Cost effective
- ▣ Left and right hand configuration
- ▣ Low power consumption

# SPECIFICATIONS

## TITANROB M501 5-F MINI MANIPLULATOR

### General technical specification

Type		TitanRob M-501 5-F Mini Manipulator
OEM		TianRob
Envirex part no		2214908 (left hand)
Depth rating	m	3 000
Weight (in air / Submerged)	kg	14 / 11
Max reach	mm	950
Lift at full extension	kg	40 @ 140bar
Max lift	kg	50 @ 140bar
Yaw grip	kgf	80
Yaw torque	Nm	45
Dimension stowed - LxWxH	mm	300 x 512 x 450
Operation temperature	°C	-5 to 55
Construction main materials		Ti6Al4V Titanium AISI 316 SS

### Functions

Shoulder Azimuth (yaw)	°	120 (+90 / -30)
Shoulder Pitch	°	108
Elbow Pitch	°	108
Jaw Rotate	°	360 continuous
Jaw Opening	mm	168

### Hydraulic requirements

Max WP	bar	140
Test pressure	bar	200
Min Flow	l/min	1,5
Max fluid temp.	°C	55
Fluids		Mineral based oils (ISO 32, etc) ** HF-Fluids on request / consult supplier.

### Dimensions

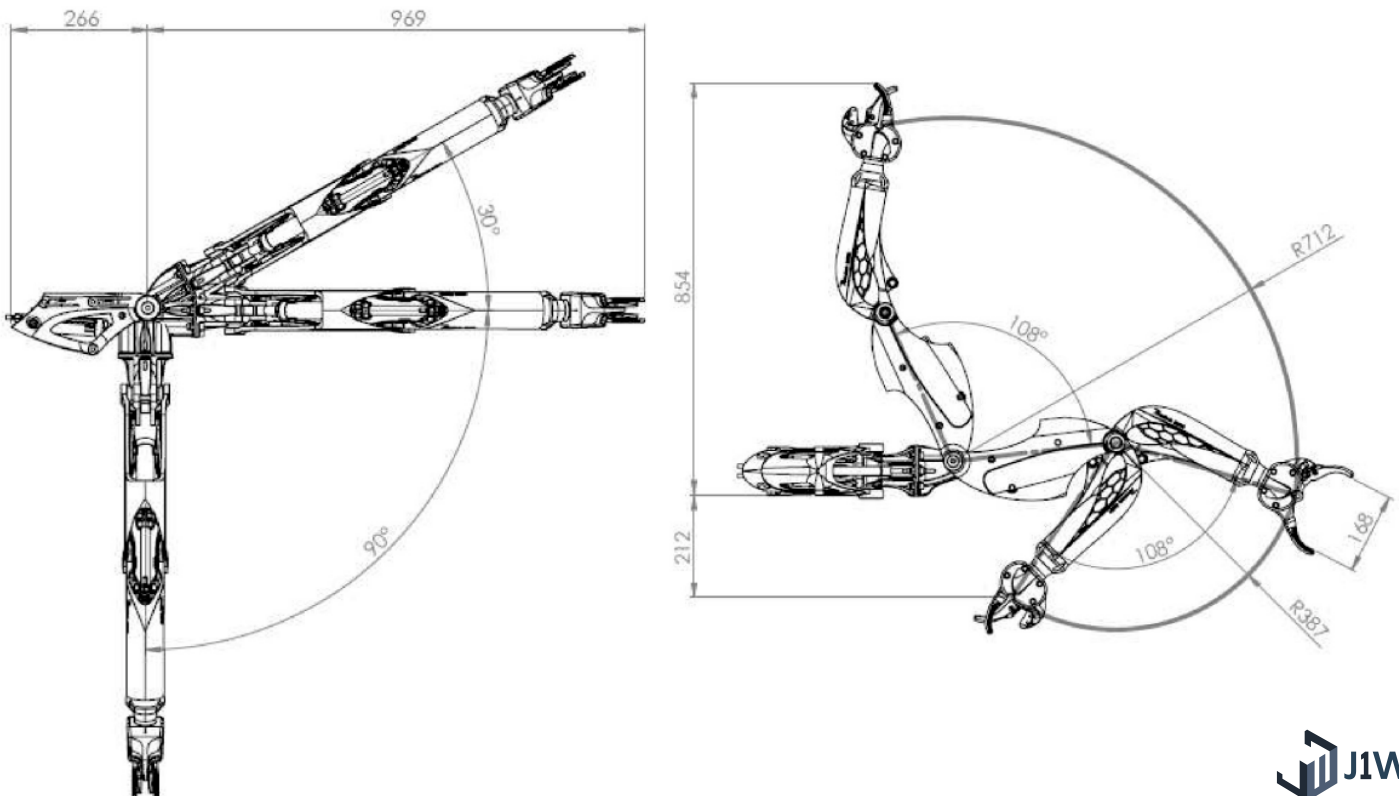

# SPECIFICATIONS

## TITANROB M501 5-F MINI MANIPULAOTR

